



# HJV STEEL

MANUFACTURER OF MECHANICAL SEALS  
& ENGINEERING PRODUCTS



📍 Gala no 38, Loheki Chawl, Momin Estate, 216/218  
Moulana Azad Road, Nagpada, Mumbai - 400008

☎ +91-9892181817 ✉ info@hjvsteel.com | sales@hjvsteel.com

1. Introduction -----	03
2. Quality Policy -----	04
3. Rubber Bellow Seals -----	05-07
4. Teflon Bellow Seals -----	08-08
5. Multi Spring Seals -----	10-13
6. Single Spring Seals -----	14-16
7. Conical Spring Seal -----	17
8. Wave Spring Seal -----	18
9. Capsulated Spring Seal -----	19
10.Metal Bellow Seals -----	20-21
11.Cartridge Seals -----	22-24
12.Double Mechanical Seals -----	25
13.Dry Seal -----	26
14.Agitator Seal -----	27
15.Seal Support System -----	28
16.Types of Mating Ring -----	29
17.Pump Process System -----	30
18.API Plans -----	31-34
19.Contact Us -----	35

# Introduction



**HJV SEALS** is engaged in the design, manufacture and installation of mechanical shaft seals for numerous applications.

HJV SEALS is one of the leading manufacturer of the mechanical seals for various pumps, compressors, agitators, reactors and mixers etc. We design the manufacture mechanical seals according to the international standards and also the products are designed using computerised equipments to avoid the errors.

HJV SEALS is committed to continuous improvement of its products and services to achieve customer's satisfaction.

HJV SEALS has been catering services to Chemical, Petrochemical, Agrochemical, Fertilizers, Pharmaceuticals Industries and many other industries.

**We believe that "The Secret of Success is Consistency of Purpose"**

## Quality :

We use best quality raw materials purchasing from India and importing from different suppliers around the world to ensure best life for our products. We actively pursuing the quality improvements through programs that enable each employee to do their job right the first time and every time. Our each products undergoes Pressure and Leak test before delivering it to our customers.

## Commitment :

We are committed to serve our customers and meet their needs and expectations by performing the task consistent and accurate way.

## Team Work :

We work together as a TEAM, encourages and support each other to achieve common and individual goals, and also respect the individual differences.

## Performance :

Based on our customers feedback we are able to design customise & manufacture mechanical seals which performed equally well to the other expensive mechanical seals brand.

## Product Range :

We have the wide range of products in mechanical seals which are highly efficient for all types of Centrifugal pumps, Compressors, Agitators, Reactors and Mixers etc. We also have the Equivalent Range of complete mechanical seals and spares for the various design like John Crane, Eagle Burgmann, Flowserve, Flexi Box and Leakproof etc.

## Services :

We provide service to our customers by taking necessary physical dimension of the equipments at the customer's site and we also provide installation and running trial service. We also maintain inventory for mechanical seals & spares for various customers manufacture at our factory to meet the customers requirement on time. We also undertake the repairs and Maintenance contracts of any third party mechanical seals.

# Quality Policy



MANUFACTURER OF MECHANICAL SEALS & ENGINEERING PRODUCTS

## Quality Policy

We at HJV SEALS (India) are committed to serve our customers and meet their needs and expectations in the design, manufacture and supply of mechanical seals & Its components by using modern management & engineering. We here are committed to continuous improvement of our products and services to achieve customer's satisfaction.

We actively pursue Quality improvements through programs that enable each employee to do their job right the first time and every time.

At HJV SEALS (India) it is Quality rather than Quantity that matters.

The goal of HJV SEALS (India) is to exceed our customer's



# Rubber Bellow Seal

## Seal Type : HJV-201RB

The Type HJV-201RB is single coil spring rubber bellow seal. Most versatile and widely used in a variety of applications as it is easy to install and economical. Shaft run out is compensated by rubber bellow and spring due to its soft aligning capability.

The unique rubber bellow secondary seal provide a high degree of axial flexibility to compensate for misalignment. Elastomeric bellow protect Shaft/Sleeve from fretting. Due to single coil spring the seal will not clogged in Effluent containing particles.

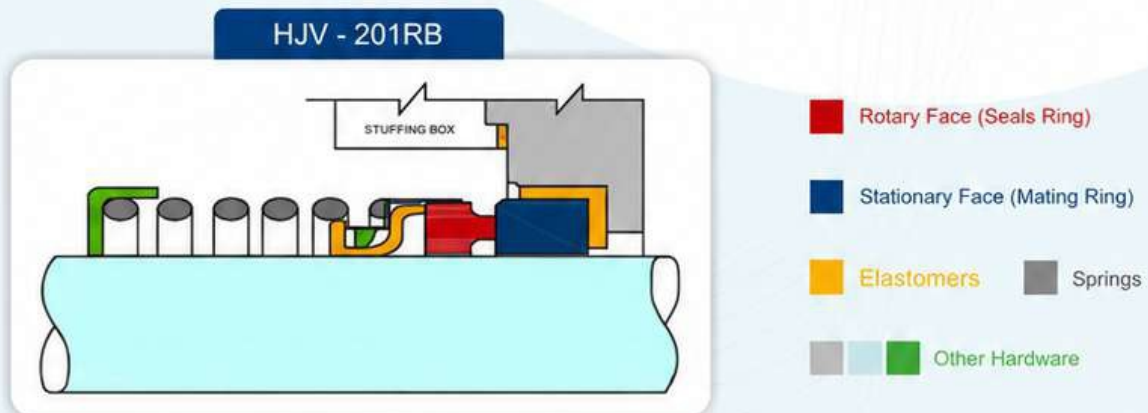

## Product Features :

- Single Acting
- Unbalanced
- Independent of Direction of Rotation
- Internally Mounted

## Applications :

- Water Pumps
- Submersible Pumps
- Sewage Pumps

## Material of Constructions :

- Seal Body : AISI 304, AISI 316
- Seal Faces : Carbon, Silicon Carbide, Ceramic
- Elastomers : Viton, EPDM, Nitrile, Neoprene

## Operating Limits :

- Pressure : upto 10 Bar
- Temperature : -20°C to +160°C
- Shaft Dia : 20mm to 100mm



MANUFACTURER OF MECHANICAL SEALS  
& ENGINEERING PRODUCTS

# Rubber Bellow Seal

## Seal Type : HJV-202RB

The Type HJV-202RB is a single coil spring rubber bellow seal used for water and sewage containing slurries. Shaft run out is compensated by rubber bellow and spring due to its self-aligning capability.

Elastomeric Bellow protects Shaft/Sleeve from Fretting. Due to single coil spring the seal will not clog in Effluent containing particles.



HJV - 202RB1

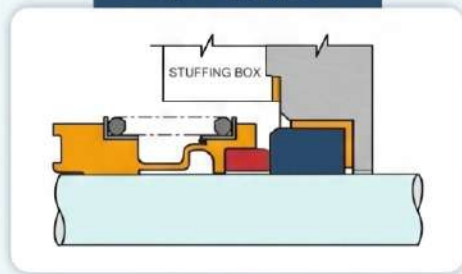

HJV - 202RB2

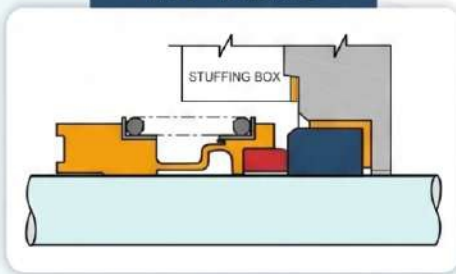

HJV - 202RB3

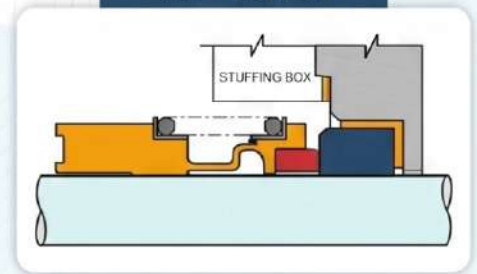

Rotary Face (Seals Ring)

Stationary Face (Mating Ring)

Elastomers

Springs

Other Hardware

### Product Features :

- Single Acting
- Unbalanced
- Independent of Direction of Rotation
- Internally Mounted

### Applications :

- Water Pumps
- Submersible Pumps
- Sewage Pumps

### Material of Constructions :

- Seal Body : AISI 304, AISI 316
- Seal Faces : Carbon, Silicon Carbide, Ceramic
- Elastomers : Viton, EPDM, Nitrile, Neoprene

### Operating Limits :

- Pressure : upto 10 Bar
- Temperature : -20°C to +160°C
- Shaft Dia : 15mm to 100mm



MANUFACTURER OF MECHANICAL SEALS  
& ENGINEERING PRODUCTS

# Rubber Bellow Seal

## Seal Type : HJV-203RB

The Type HJV-203RB is single coil spring rubber bellow seal used for water and oil containing slurries. Shaft run out is compensated by rubber bellow and spring due to its self aligning capability.

Elastomeric bellow protect Shaft/Sleeve from Fretting. Due to single coil spring the seal will not clogged in Effluent containing particles.

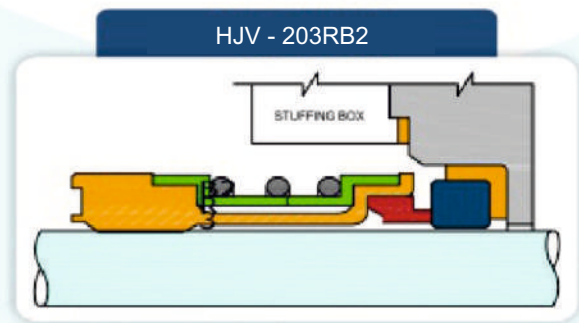
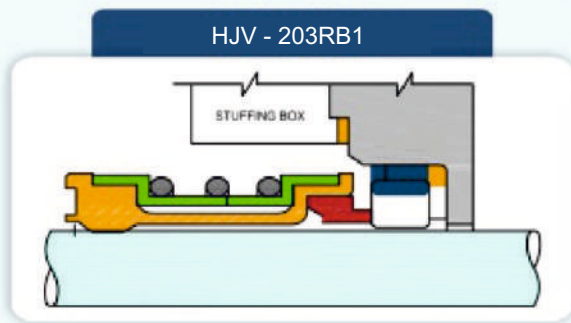

### Product Features :

- Single Acting
- Unbalanced
- Independent of Direction of Rotation
- Internally Mounted

### Material of Constructions :

- Seal body : AISI 304, AISI 316
- Seal Faces : Carbon, Silicon Carbide, Ceramic
- Elastomers : Viton, EPDM, Nitrile, Neuprene

### Operating Limits :

- Pressure : upto 10 Bar
- Temperature : -20°C to +160°C
- Shaft Dia : 15mm to 100mm

### Applications :

- Water Pumps
- Submersible Pumps
- Sewage Pumps



MANUFACTURER OF MECHANICAL SEALS  
& ENGINEERING PRODUCTS

# Teflon Bellow Seal

## Seal Type : HJV-301TB

The Type HJV-301TB is Externally mounted low pressure mechanical seal with metal free contact parts due to corrosive pumping media. Series HJV-301TB is designed for highly corrosive chemicals such as concentrated acids, chemically active organic compound, Corrosive and Abrasive liquid.

This seals are independent of direction of rotation. Seal ring face can be changed or replaced due to its design feature. The face is positively driven by integral lugs which is on bellow, it imparts smooth drive to the face.

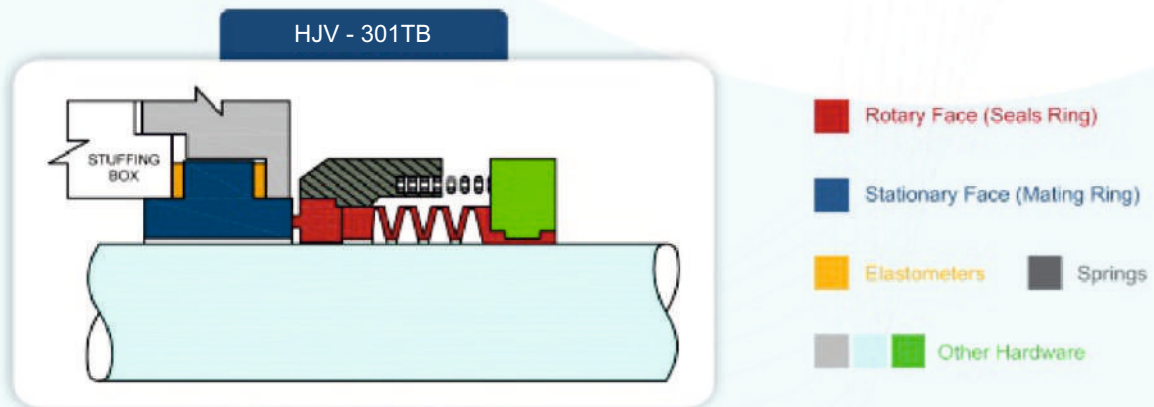

### Product Features :

- Single Acting
- Independent of Direction of Rotation
- Internally Mounted

### Applications :

- Extremely Corrosive Services
- Acids & Alkalies

### Material of Constructions :

- Seal body : AISI 316, Alloy-20, Hastelloy C
- Seal Faces : Carbon, Silicon Carbide, Ceramic ( 99.5% ), PTFE, GFT, CFT
- Springs : AISI 316, Alloy-20, Hastelloy C
- Elastomers : PTFE, GFT, CFT

### Operating Limits :

- Pressure : upto 6 Bar
- Temperature : -20°C to +100°C
- Shaft Dia : 18mm to 100mm



MANUFACTURER OF MECHANICAL SEALS  
& ENGINEERING PRODUCTS

# Teflon Bellow Seal

## Seal Type : HJV-302TB

The Type HJV-302TB is Externally mounted low pressure mechanical seal with metal free contact parts due to corrosive pumping media. Series HJV-302TB is designed for highly corrosive chemicals such as concentrated acids, chemically active organic compound, Corrosive and Abrasive liquid.

This seals are independent of direction of rotation. Seal ring face can be changed or replaced due to its design feature. The face is positively driven by integral lugs which is on bellow, it imparts smooth drive to the face.

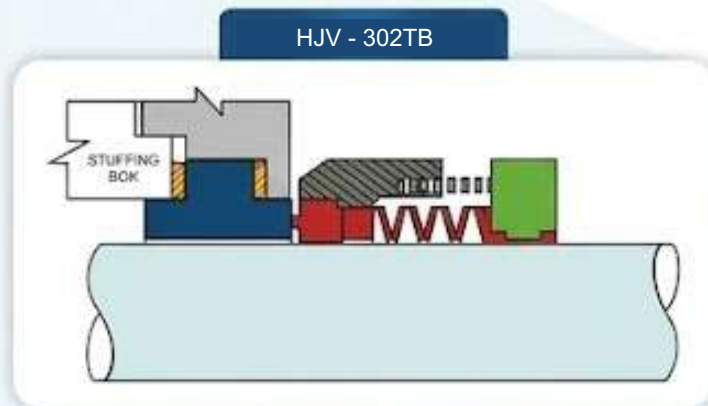

### Product Features :

- Single Acting
- Independent of Direction of Rotation
- Internally Mounted

### Applications :

- Extremely Corrosive Services
- Acids & Alkalies

### Material of Constructions :

- Seal body : AISI 316, Alloy-20, Hastelloy C
- Seal Faces : Carbon, Silicon Carbide, Ceramic ( 99.5% ), PTFE, GFT, CFT
- Springs : AISI 316, Alloy-20, Hastulloy C
- Elastomers : PTFE, GFT, CFT

### Operating Limits :

- Pressure : upto 6 Bar
- Temperature : -20°C to + 100°C
- Shaft Dia : 18mm to 100 mm



MANUFACTURER OF MECHANICAL SEALS  
& ENGINEERING PRODUCTS

# Multi Spring Seal

## Seal Type : HJV-101U & HJV-101W

The Series HJV-101 are multi spring mechanical seal made for various applications. It's compact Design is easy to install and also easy for maintenance. This seals are independent of direction of rotation.

For easy installation and removal of the seal, all components are held together with the snap ring. All parts are interchangeable, one can easily convert 101U to 101W by changing its seal ring and secondary seal. This concept is ideal for Stock rationalization.

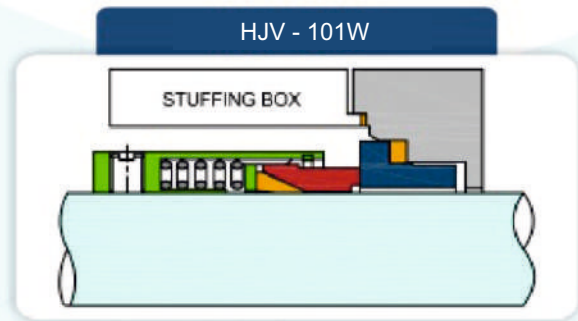
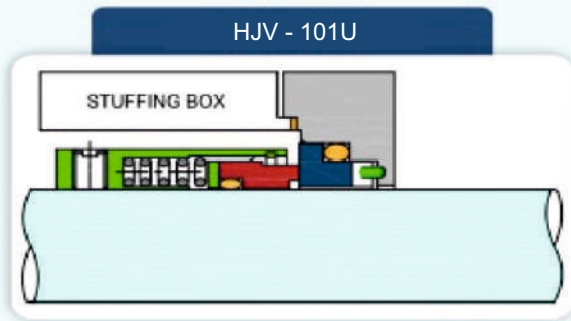

### Product Features :

- Single Acting
- Independent of Direction of Rotation
- Internally Mounted
- Unbalanced

### Applications :

- Petrochemicals
- Petroleum Refinery
- General Chemicals
- Light Hydrocarbon

### Material of Constructions :

- Seal body : AISI 304, AISI 316, Hastelloy-C, Alloy-20
- Seal Faces : Carbon, Silicon Carbide, Ceramic ( 99.5% ), Tungsten Carbide
- Elastomers :
- MSI-101U : Viton, EPDM, TTV, FEP, Aflas, Kalrez
- MSI-101W : PTFE, GFT

### Operating Limits :

- Pressure : upto 6 Bar
- Temperature : -20°C to +200°C
- Shaft Dia : 12mm to 100mm



MANUFACTURER OF MECHANICAL SEALS  
& ENGINEERING PRODUCTS

# Multi Spring Seal

## Seal Type : HJV-102B

The type HJV-102B is multi spring externally mounted balanced mechanical seal. It has 'O' Ring as a Secondary Sealing member. This seal are independent of direction of rotation.

Due to it's design it can be use for corrosive services as its metallic components like thrust ring, springs, retainer body etc does not come in direct contact of fluid.

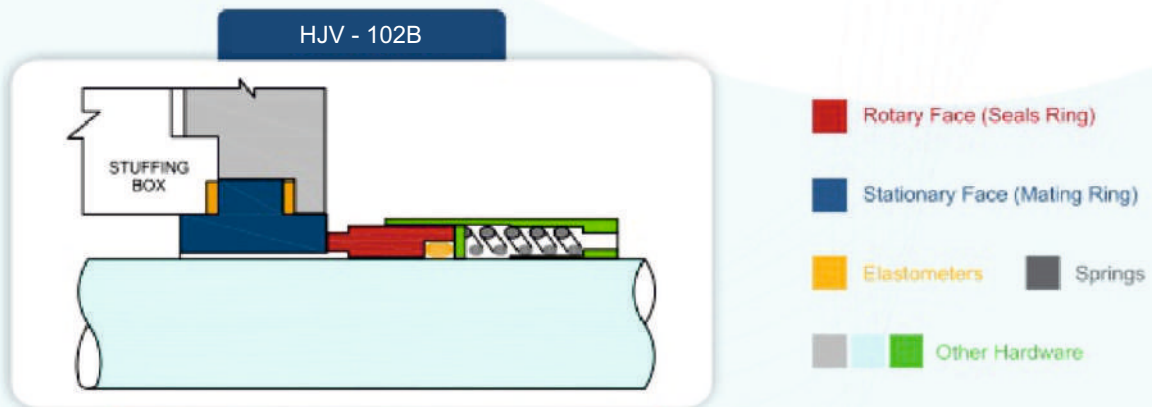

### Product Features :

- Single Acting
- Independent of Direction of Rotation
- Internally Mounted
- Balanced

### Applications :

- Corrosive Services
- Acids & Alkalies
- Petrochemicals
- General & Light Chemicals

### Material of Constructions :

- Seal body : AISI 304, AISI 316, Hastelloy-C, Alloy-20
- Seal Faces : Carbon, Silicon Carbide, Ceramic ( 99.5% ), Tungsten Carbide
- Elastomers : Viton, EPDM, TTV, FEP, Aflas, Kalrez, PTFE, GFT, CFT

### Operating Limits :

- Pressure : upto 8 Bar
- Temperature : -20°C to + 180°C
- Shaft Dia : 12mm to 100mm



MANUFACTURER OF MECHANICAL SEALS  
& ENGINEERING PRODUCTS

# Multi Spring Seal

## Seal Type : HJV-103BO & HJV-103BW

The Series HJV-103 are multi spring seals used for universal applications. It is internally mounted balance mechanical seal. It may install to all types of centrifugal pumps due to its compact design.

By changing it's seal ring component it can be easily convert to 'Wedge type' (HJV-103BW) from 'O' Ring type (HJV-103BO) or vice versa depends on it's application.

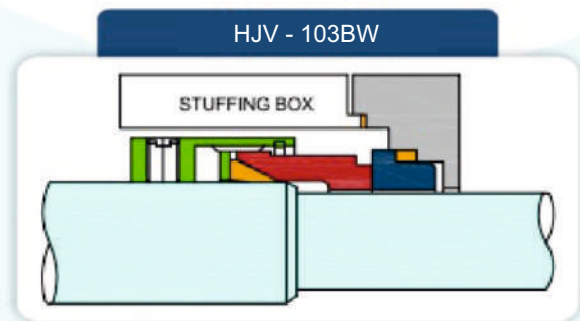
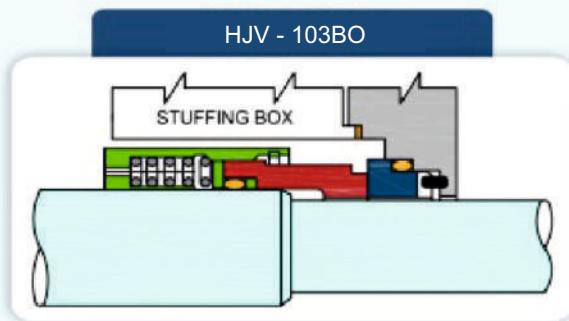

Rotary Face (Seals Ring)

Stationary Face (Mating Ring)

Elastomers

Springs

Other Hardware

### Product Features :

- Single Acting
- Independent of Direction of Rotation
- Internally Mounted
- Balanced

### Applications :

- Petrochemicals
- Petro Refinery
- General Chemicals
- Light Hydrocarbon

### Material of Constructions :

- Seal body : AISI 304, AISI 316, Hastelloy-C, Alloy-20
- Face Material : Carbon, Silicon Carbide, Ceramic ( 99.5% ), Tungsten Carbide
- Elastomers :
- MSI-103BO : Viton, EPDM, TTV, FEP, Aflas, Kalrez
- MSI-103BW : PTFE, GFT, CFT

### Operating Limits :

- Pressure : upto 35 Bar
- Temperature : -20°C to + 200°C
- Shaft Dia : 12mm to 100mm



MANUFACTURER OF MECHANICAL SEALS  
& ENGINEERING PRODUCTS

# Multi Spring Seal

## Seal Type : HJV-104U, HJV-105U, HJV-104B & HJV-105B

This Series HJV-104 & HJV-105 are multi spring Balanced and Unbalanced designed mechanical seal. This seals are independent in the direction of rotation.

Multi spring design exerts uniform pressure on seal faces and balances primary ring makes it suitable for high pressure. It may install to all types of centrifugal pumps.

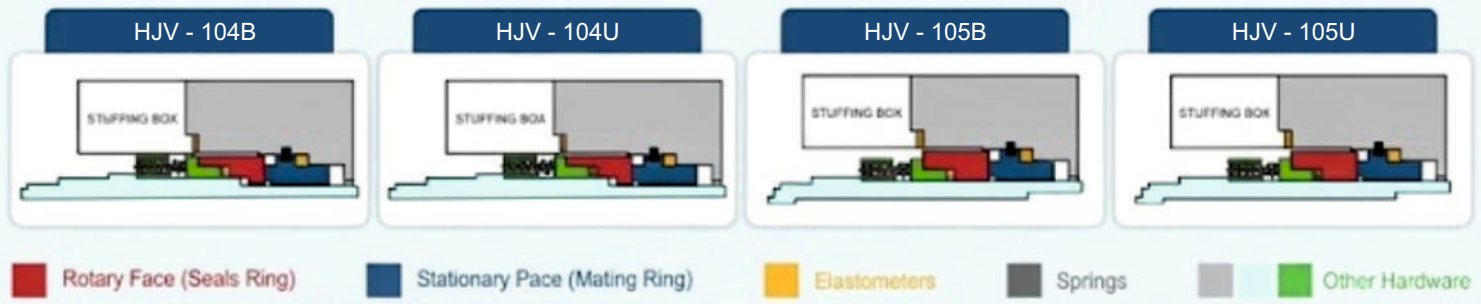

### Product Features :

- Single Acting
- Independ of Direction of Rotation
- Balanced & Unbalanced

### Applications :

- Petrochemicals
- Petro Refinery
- General Cenericals
- Light Hydrocarbon

### Material of Constructions :

- Seal body : AISI 304, AISI 316, Hastelley-C, Alloy-20
- Face Material : Carbon, Silicon Carbide, Ceramic ( 99.5% ), Tungsten Carbiée
- Elastomers :
- HJV-104B / 104U : Viton, EPDM, TTV, FEP, Atlas, Kairez
- HJV-105B / 105U : PTFE, GFT, GFT

### Operating Limits :

- Pressure : Unbalance Seal 06 bar & Balance Seal upto 30 bar
- Temperature : -20°C to + 200°C
- Shaft Dia : 15mm to 100mm



MANUFACTURER OF MECHANICAL SEALS  
& ENGINEERING PRODUCTS

# Single Spring Seal

## Seal Type : HJV-107

The Series 107 is single coil Unbalance mechanical seal. It is internally mounted mechanical seal and also easy to install. It is dependent in the direction of shaft rotation. Clockwise rotating shaft required right handed spring & Anticlockwise rotating shaft required left handed spring.

It is simple in construction. Rotary seal ring is driven by the motion transmitted by the shaft to the spring.

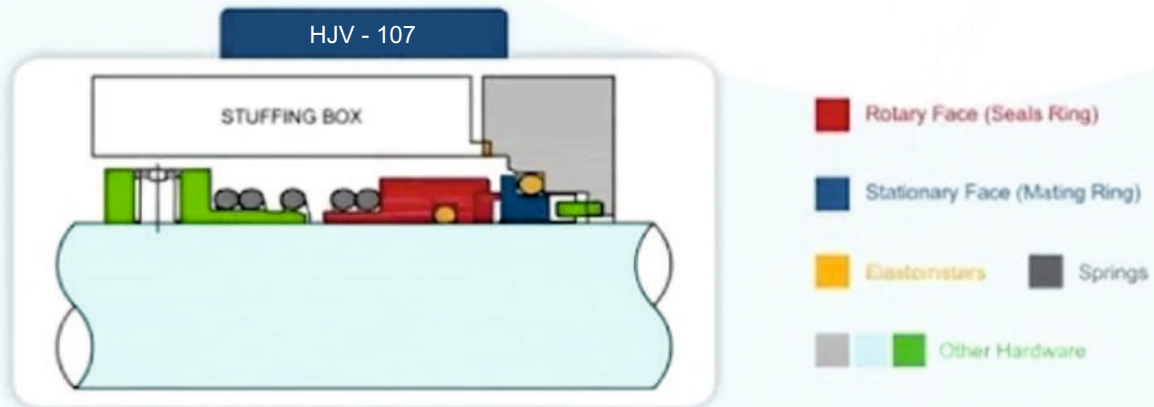

### Product Features :

- Single Acting
- Dependent of Direction of Rotation
- Unbalanced
- Internally Mounted

### Applications :

- Dirty Water & Slurry
- Petroleum Refinery
- General Chemicals

### Material of Constructions :

- Seal body : AISI 304, AISI 316, Hastelloy-C, Alloy-20
- Face Material : Carbon, Silicon Carbide, Ceramic ( 99.5% ), Tungsten Carbide
- Elastomers : Viton, EPDM, TTV, FEP, PTFE, Afias, Kalrez

### Operating Limits :

- Pressure : upto 06 Bar
- Temperature : -20°C to +200°C
- Shaft Dia : 15mm to 100mm



MANUFACTURER OF MECHANICAL SEALS  
& ENGINEERING PRODUCTS

# Single Spring Seal

## Seal Type : HJV-108U & HJV-108V

The Series 108 is bidirectional single spring Unbalance mechanical seal. This series of mechanical seal are design for the dirty media type applications. It is Independent in the direction of rotation. It is simple in construction and easy to install.

Torque transmission for seal ring will be done through its drive lug. All parts of the Seal are Interchangeable, one can easily convert HJV-108V to HJV-108U only by changing it's Elastomers.

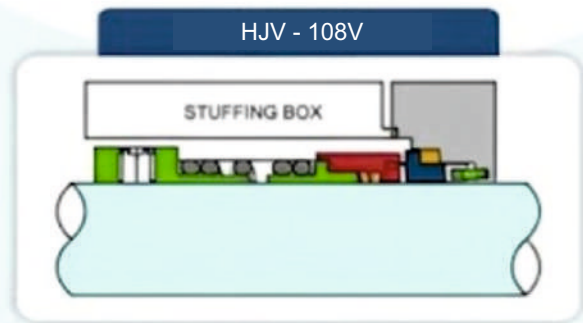
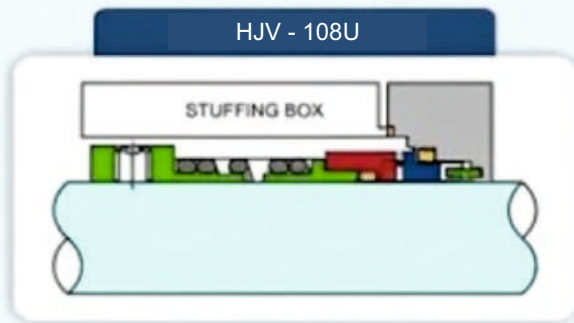

Rotary Face (Seals Ring)

Stationary Face (Mating Ring)

Elastomers

Springs

Other Hardware

### Product Features :

- Single Acting
- Independent of Direction of Rotation
- Unbalanced

### Applications :

- Crystallizing Slurry
- Dirty Water & Slurry
- Petroleum Refinery

### Material of Constructions :

- Seal body : AISI 304, AISI 316, Hastelloy-C, Alloy-20
- Face Material : Carbon, Silicon Carbide, Ceramic ( 99.5% ), Tungsten Carbide
- Elastomers :
- HJV-108U : Viton, EPDM, TTV, FEP, Aflas, Kairez
- HJV- 108V : PTFE, GFT, CFT

### Operating Limits :

- Pressure : upto 06 Bar
- Temperature : -20°C to +200°C
- Shaft Dia : 15mm to 100mm



MANUFACTURER OF MECHANICAL SEALS  
& ENGINEERING PRODUCTS

# Single Spring Seal

## Seal Type : HJV-109U & HJV-109W HJV-110U & HJV-110W

The Series 109 & 110 are single Balance & Unbalance internally mounted mechanical seal. This series of mechanical seal are design for the dirty media type applications.

It is Independent in the direction of rotation. For easy installation and removal all component of the seal are held together by snap ring.

All parts of the seal are interchangeable, one can convert HJV-109U to HJV-109W and HJV-110U to HJV-110W only by changing it's seal ring and it's elastomer. This is ideal for stock rationalization.

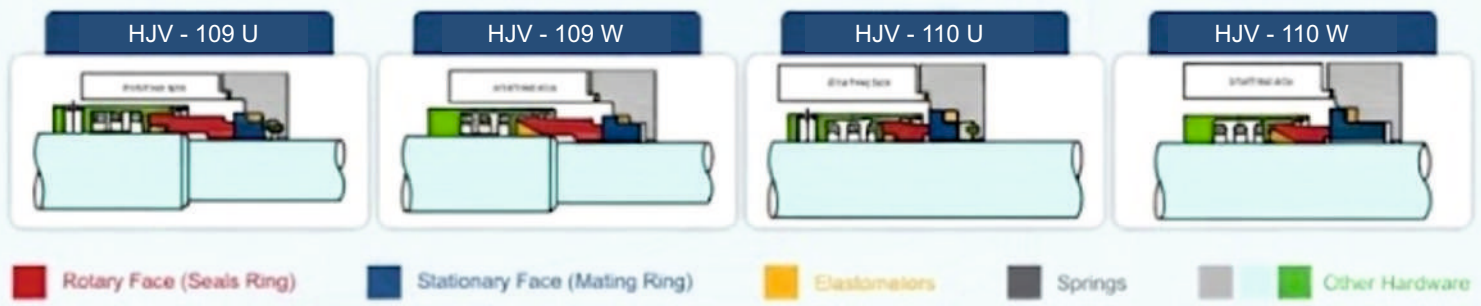

### Product Features :

- Single Acting
- Independent of Direction of Rotation
- Balance & Unbalance
- Internally Mounted

### Applications :

- Petrochemicals
- Petroleum Refinery
- General Chemical

### Material of Constructions :

- Seal body : AISI 304, AISI 316, Hastelloy-C, Alloy-20
- Face Material : Carbon, Silicon Carbide, Ceramic ( 99.5% ), Tungsten Carbide
- Elastomers :
- HJV-109U / 110U : Viton, EPDM, TTV, FEP, Aflas, Kalrez
- HJV-109W / 110W : PTFE, GFT, CFT

### Operating Limits :

- Pressure : Unbalance upto 08 Bar, Balance upto 30 Bar
- Temperature : -20°C to +200°C
- Shaft Dia : 15mm to 100mm



MANUFACTURER OF MECHANICAL SEALS  
& ENGINEERING PRODUCTS

# Conical Spring Seal

## Seal Type : HJV-401U

The Series 401 is a single conical unbalance mechanical seal. These type of seals are dependent of shaft direction of rotation. Clockwise rotating Shaft Required Right Handed Spring & Anticlockwise rotating Shaft Required Left Handed Spring.

The Rotating Shaft transmit the torque to the spring. This seal are easy to install.

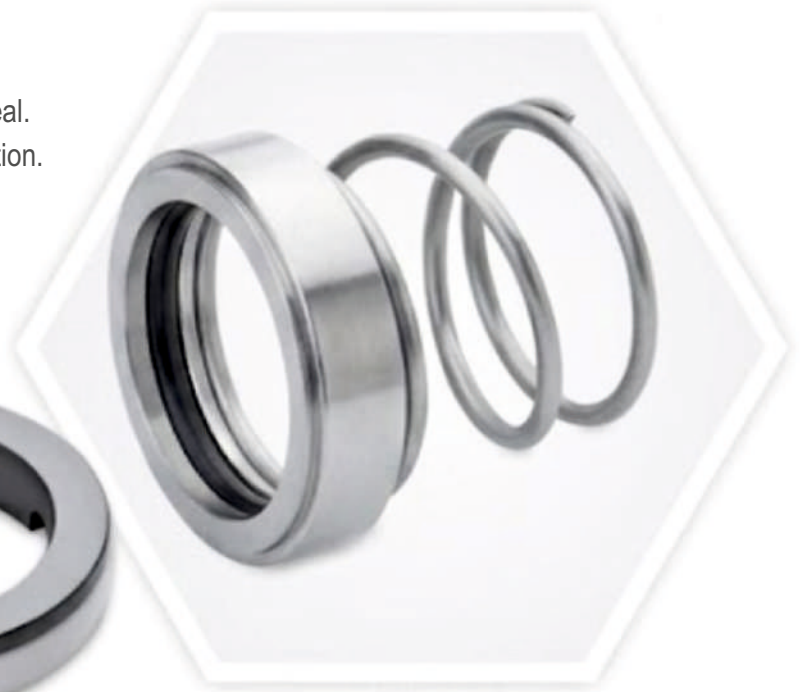
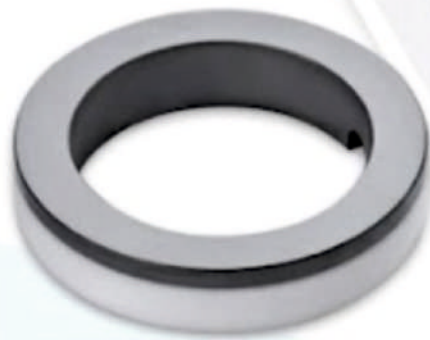

HJV - 401 U

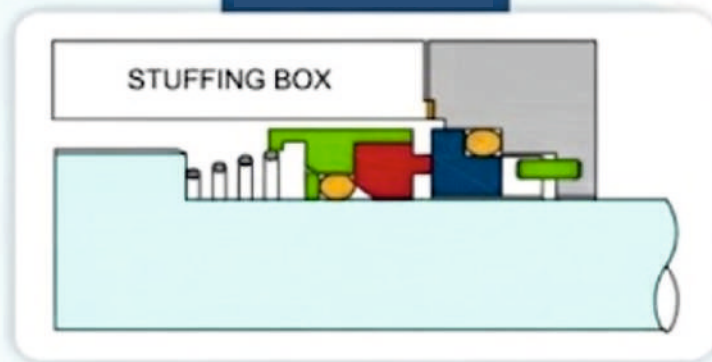

### Product Features :

- Dependent of Direction of Rotation
- Unbalanced
- Internally Mounted

### Applications :

- Water Pumps
- Chemical Process pumps
- Petroleum Refinery

### Material of Constructions :

- Seal body : AISI 304, AISI 316  
Face Material : Carbon, Silicon Carbide, Ceramic ( 99.5% ), Tungsten Carbide  
Elastomers : Viton, EPDM, Nitro, Neuprene, Afias

### Operating Limits :

- Pressure : upto 08 Bar  
Temperature : -20°C to +200°C  
Shaft Dia : 10mm to 100mm



MANUFACTURER OF MECHANICAL SEALS  
& ENGINEERING PRODUCTS

# Wave Spring Seal

## Seal Type : HJV-501U & HJV-501W

The Series HJV-501 is single Wave springs seal designed for universal applications and ideal suited for standardization. The main advantage of these seal is that it has a wave spring which is laterally stable, lightweight, compact, and easy to install.

Torque transmission will be done by retainer shell punch to seal ring. These seals are also used in Dirty applications as spring clogging does not occurs. One can convert HJV-501U to HJV-501W by changing only it's Seal Ring & Elastomers. This is ideal for stock rationalization

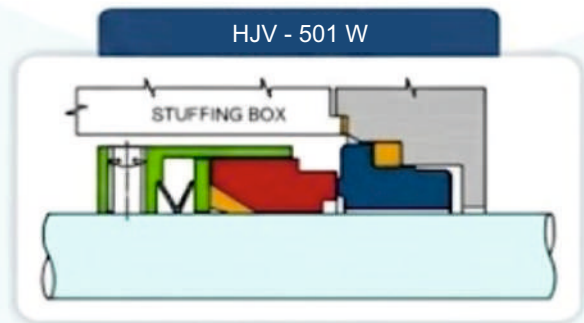
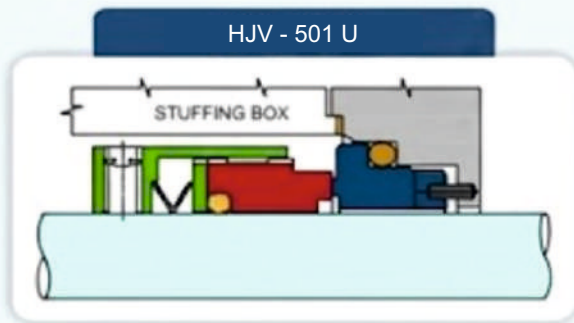

Rotary Face (Seals Ring)

Stationary Face (Mating Ring)

Elastomers

Springs

Other Hardware

### Product Features :

- Independent of Direction of Rotation
- Unbalanced
- Internally Mounted

### Applications :

- Abrasive & Sewage handling pumps
- High Viscosity Handling pumps
- General Chemicals Application

### Material of Constructions :

- Seal body : AISI 304, AISI 316
- Face Material : Carbon, Silicon Carbide, Tungsten Carbide, Ceramic ( 99.5% )
- Elastomers :
- HJV-501U : Viton, EPDM, TTV, FEP, Aflas, Kalrez
- HJV-501W : PTFE, GFT, CFT

### Operating Limits :

- Pressure : upto 10 Bar
- Temperature : -20°C to +200°C
- Shaft Dia : 15mm to 100mm



MANUFACTURER OF MECHANICAL SEALS  
& ENGINEERING PRODUCTS

# Capsulated Spring Seal

## Seal Type : HJV-1010

The Type HJV-1010CS is capsulated balance seal designed for media containing solid slurry particles. The springs are protected from solidifying media resulting in high reliability of the seal. This seals are independent of direction of rotation.

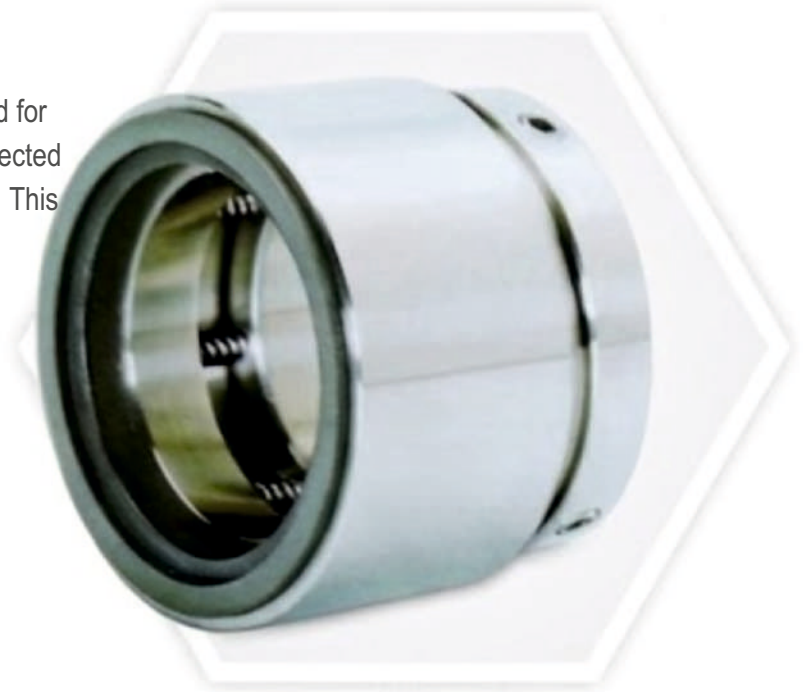

HJV - 201RB

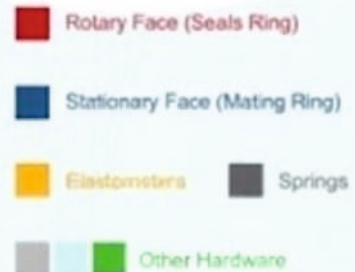
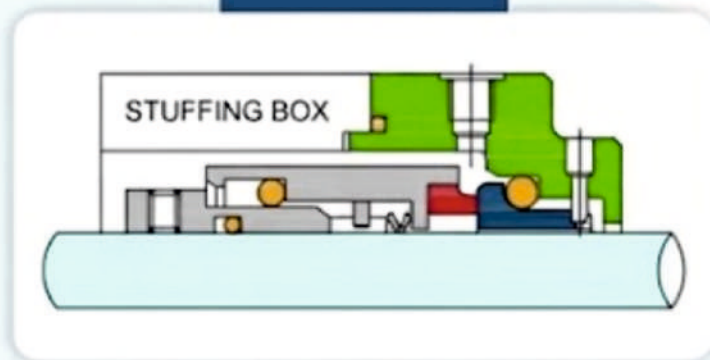

### Product Features :

- Single Acting
- Capsulated Spring
- Independent of Direction of Rotation

### Applications :

- General Chemicals
- Media Containing solids particles
- Acids & Alkalies

### Material of Constructions :

- Seal body : AISI 316, Alloy-20, Hastelloy C
- Seal Faces : Carbon, Silicon Carbide, Ceramic ( 99.5% ), PTFE, GFT, CFT
- Springs : AISI 316, Alloy-20, Hastelloy C
- Elastomers : Viton, EPDM, TTV, FEP, Allas, Kalrez

### Operating Limits :

- Pressure : upto 6 Bar
- Temperature : -20°C to +100°C
- Shaft Dia : 18 to 100mm

# Metal Bellow Seal

## Seal Type : HJV-601

The Series 601 are specially developed mechanical seal suitable for high temperature. The bellow is constructed by welding a series of diaphragms together at the edges. Each welded set of plates has a fixed axial movement along the shaft.

Type 601 having a grafoil, is used as a secondary member having excellent temperature range upto 400°C. It has an shrunk fit seal face which minimize face distortion. And in type 602U having 'O' ring due to change in its application. Bellow will eliminates the need of spring and provide flexibility to the seal.

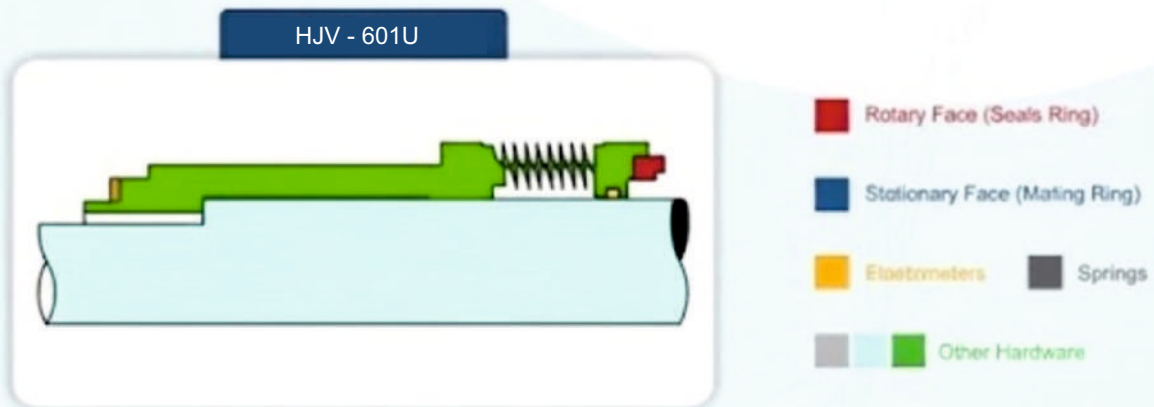

### Product Features :

- Self cleaning, non-clogging construction
- Highly corrosion resistant
- High performance
- Easy to install

### Applications :

- Petrochemicals
- Refineries
- Soap Plant
- Chemical Plants

### Material of Constructions :

- Seal body : SS 316, Carpenter-42, Alloy 20, Hastelloy-C
- Material of bellow : AM 350 & Inconel 625
- Face Material : Carbon, Silicon Carbide, Tungsten Carbide
- Elastomers : Viton, Atlas, Grafoil, Kalrez.

### Operating Limits :

- Pressure : upto 18 Bar
- Temperature : -20°C to + 400°C
- Shaft Dia : 20mm to 100mm



MANUFACTURER OF MECHANICAL SEALS  
& ENGINEERING PRODUCTS

# Metal Bellow Seal

## Seal Type : HJV-602

The Series HJV-602 are specially developed mechanical seal suitable for high temperature. The bellow is constructed by welding a series of diaphragms together at the edges. Each welded set of plates has a fixed axial movement along the shaft.

Type 602G having a grafoil, is used as a secondary member having excellent temperature range upto 400°C. It has a shrunk fit seal face which minimize face distortion. And in type 602U having 'O' ring due to change in its application. Bellow will eliminates the need of spring and provide flexibility to the seal.

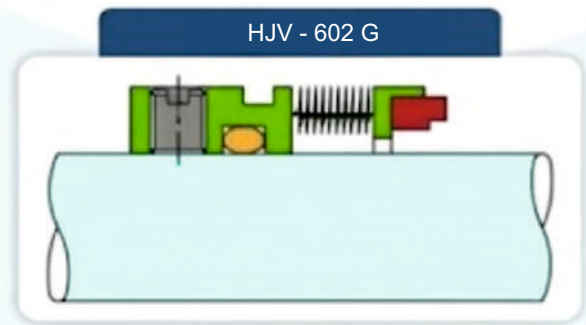
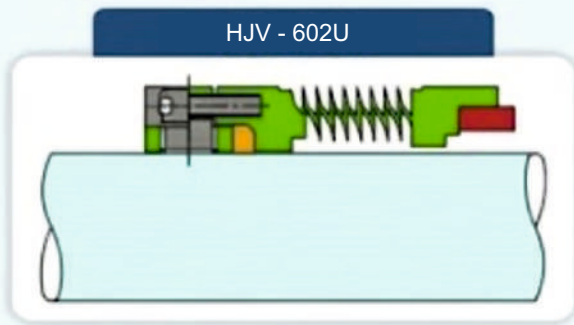

Rotary Face (Seals Ring)

Stationary Face (Mating Ring)

Elastomers

Springs

Other Hardware

### Product Features :

- Self cleaning, non-clogging construction
- Highly corrosion resistant
- High performance
- Easy to install

### Applications :

- Petrochemicals
- Refineries
- Soap Plant
- Chemical Plants

### Material of Constructions :

Seal body	: SS 316, Carpenter-42, Alloy 20, Hastelloy-C
Material of bellow	: AM 350 & Inconel 625
Face Material	: Carbon, Silicon Carbide, Tungsten Carbide
Elastomers	: Viton, Aflas, Grafoil, Kalrez.
HJV-602 G	: HJV-602 U
Face Material	: Carbon, Silicon Carbide, Tungsten Carbide
Elastomers	: Viton, Aflas, Grafoil, Kalrez.

### Operating Limits :

Pressure	: upto 18 Bar
Temperature	: -20°C to + 400°C
Shaft Dia	: 20mm to 100mm



MANUFACTURER OF MECHANICAL SEALS  
& ENGINEERING PRODUCTS

# Cartridge Seal

## Seal Type : HJV-CT701

The HJV-CT701 type is a simple-to-install, unitized cartridge mounted mechanical seal which requires no measuring for installation. The seal faces are protected from damage and contamination from dirt and foreign particles and are widely used in Grundfos pumps.

These types of seals are designed for pumps handling slurries, syrups and other fluids that solidify or polymerized with the change in temperature.



HJV - CT701

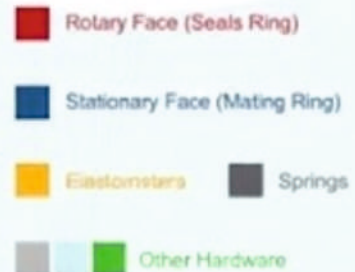
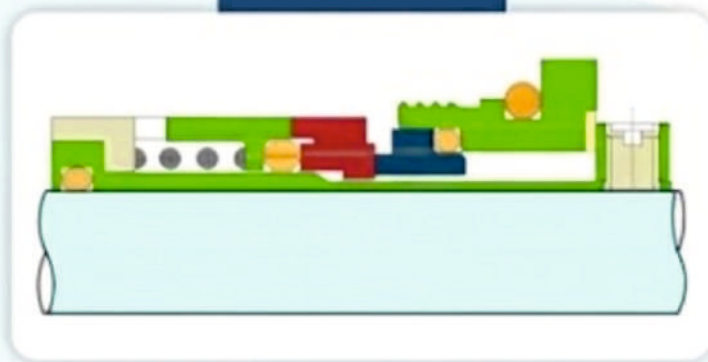

### Product Features :

- Single Acting.
- Independent of Direction of Rotation.
- Easy to install
- Cartridge Design.

### Applications :

- Slurry pumps
- Pulp & paper
- Petrochemicals, Refineries
- General Chemicals.

### Material of Constructions :

- Seal body : AISI 304, AISI 316
- Face Material : Carbon, Silicon Carbide, Ceramic ( 99.5% ), Tungsten Carbide
- Elastomers : Viton, EPDM, Nitrile, Neuprene, Aflas, PTFE, GFT

### Operating Limits :

- Pressure : upto 05 Bar
- Temperature : -20°C to + 180°C
- Shaft Dia : 12mm to 22mm

# Cartridge Seal

## Seal Type : CT702B

The HJV-CT702B type is a simple-to-install, unitized cartridge mounted, balanced, multiple spring mechanical seal which requires no measuring for installation. The seal faces are protected from damage and contamination from dirt and foreign particles.

Simply slide the seal onto the shaft, bolt down the gland, tighten the set screws, and remove the location plate. The seal faces are positioned in the gland for maximum protection. The flush position maximizes face cooling.



HJV - CT702B

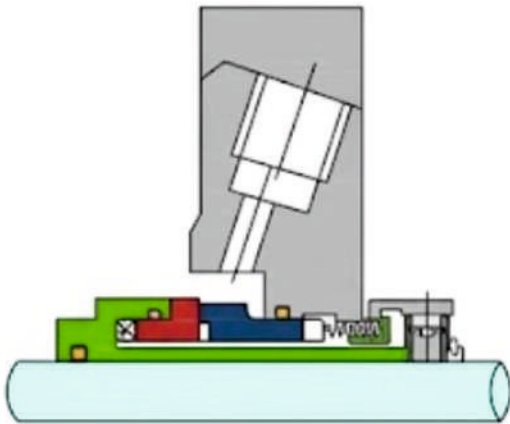

### Product Features :

- Single Acting
- Independent of Direction of Rotation
- Easy to install
- Cartridge Design

### Applications :

- Sludge & Syrup pump
- Petroleum Refinery
- Chemical, Refineries

### Material of Constructions :

- Seal body : AISI 304, AISI 316, Hast C\*, Alloy-20
- Face Material : Carbon, Silicon Carbide, Tungsten Carbide, Ceramic (99.5%)
- Elastomers : Viton, EPDM, Nitrile, Neuprene, Atlas, Kalrez, PTFE, GFT

### Operating Limits :

- Pressure : 5 to 25 Bar
- Temperature : -20°C to + 200°C
- Shaft Dia : 20mm to 100mm



MANUFACTURER OF MECHANICAL SEALS  
& ENGINEERING PRODUCTS

# Cartridge Seal

## Seal Type : HJV-CT703

The HJV-CT703 type is a simple-to-install, unitized cartridge mounted, balanced, multiple spring mechanical seal which requires no measuring for installation. The seal faces are protected from damage and contamination from dirt and foreign particles.

Simply slide the seal onto the shaft, bolt down the gland, tighten the set screws, and remove the location plate. The seal faces are positioned in the gland for maximum protection. The flush position maximizes face cooling.



### Product Features :

- Single Acting
- Independent of Direction of Rotation
- Easy to install
- Cartridge Design

### Applications :

- Sludge & Syrup Pump
- Petroleum Refinery
- Chemical, Refineries

### Material of Constructions :

- Seal body : AISI 304, AISI 316, Hast'C', Alloy-20
- Face Material : Carbon, Silicon Carbide, Tungsten Carbide, Ceramic ( 99.5% )
- Elastomers : Viton, EPDM, Nitrile, Neuprene, Aflas, Kalrez, PTFE, GFT

### Operating Limits :

- Pressure : 5 to 25 Bar
- Temperature : -20°C to + 200°C
- Shaft Dia : 20mm to 100mm



MANUFACTURER OF MECHANICAL SEALS  
& ENGINEERING PRODUCTS

# Double Mechanical Seal

## Seal Type : HJV-1020

The Series HJV-1020 are multi spring double mechanical seal design where absolute leak proof sealing is necessary due to toxic, hazardous nature of fluid. This seals is a combination of two conventional seals installed back to back inside stuffing box.

The inner seal prevents the circulated fluid to enter the system and the outer seal prevents it from leaking it to atmosphere. The circulation of the fluid reduces the heat generated on the seal faces. This seals are available in different design combination suiting to service conditions.



### Product Features :

- Single Acting
- Independent of Direction of Rotation
- Internally Mounted
- Back to Back Design

### Applications :

- Petrochemicals
- Petro Refinery
- General Chemicals

### Material of Constructions :

- Seal body : AISI 304, AISI 316, Hastelloy-C, Alloy-20
- Face Material : Carbon, Silicon Carbide, Ceramic ( 99.5% ), Tungsten Carbide
- Elastomers : Viton, EPDM, TTV, FEP, Aflas, Kalrez, PTFE, GFT,CFT.

### Operating Limits :

- Pressure : upto 30 Bar
- Temperature : -20°C to +200°C
- Shaft Dia : 12mm to 100mm



MANUFACTURER OF MECHANICAL SEALS  
& ENGINEERING PRODUCTS

# Dry Seal

## Seal Type : HJV-B801

Type HJV-B801 design are basically used as dry running seals and can be used for corrosive services. The Advantage of these Seals are that it does not require any lubricant or Quenching for cooling.

These seals are use for mixers, agitators and reactors for clean ability. These seals were developed for sanitary applications where product contamination from barrier fluids is unacceptable. Hence this Seals are used.



HJV - BB01

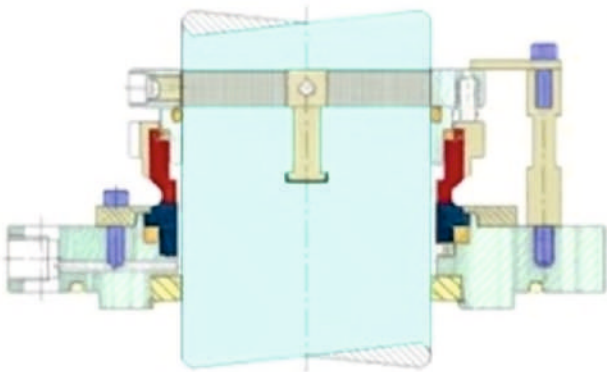

### Product Features :

- Single Acting
- Independent of Direction of Rotation
- Easy to install

### Applications :

- Corrosive Applications
- Pharma Reactors
- Petroleum Refinery
- General Chemicals

### Material of Constructions :

- Seal body : AISI 304, AISI 316, Hast'C', Alloy-20
- Face Material : Carbon, Silicon Carbide, Tungstan Carbide, Ceramic ( 99.5% ),
- Elastomers : Viton, Afias, FEP, Kalrez,, TTV, PTFE, GFT

### Operating Limits :

- Pressure : upto 10 Bar
- Temperature : upto 120°C
- Shaft Dia : 20mm to 150mm



MANUFACTURER OF MECHANICAL SEALS  
& ENGINEERING PRODUCTS

# Agitator Seal

## Seal Type : HJV-AG900

The AG900 Agitator seals are design for handling severe services including products emitting highly toxic vapours during Reaction process. Packed in one compact, unitized cartridge assembly design which is easy for installation. These Seals are independent in the Direction of Rotation used in various type of Equipment like Agitator, Reactors, Mixers & Glass line vessel. The Jacketed Cooling also helps to maintain the cool environment around the seal. This seal are also supported by the Thermosyfan system to maintain the temperature & pressure inside the Seal Housing.



HJV - AG900

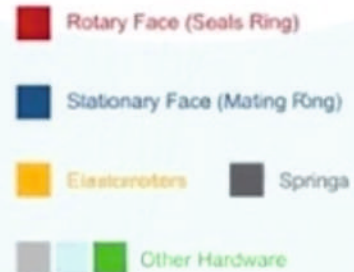
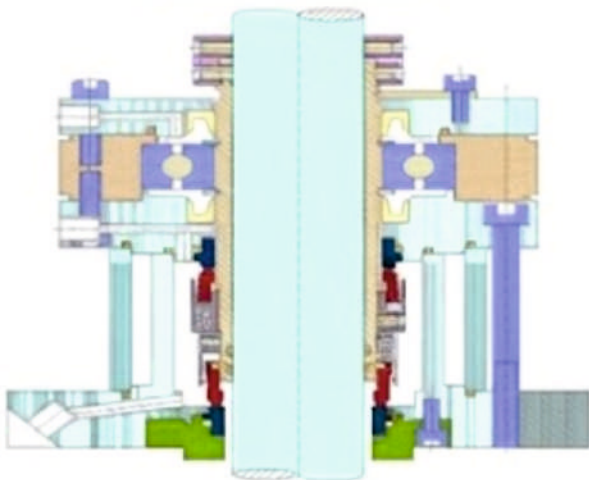

### Product Features:

- Single Acting
- Independent of Direction of Rotation
- Easy to install
- Cartridge Design

### Applications:

- Petrochemicals
- Light hydrocarbon
- General chemical etc.

### Material of Constructions:

- Seal body : AISI 304, AISI 316, Hast C, Alloy-20
- Face Material : Carbon / Silicon Carbide / Ceramic ( 99.5% ), Tungsten Carbide
- Elastomers : Viton, Aflas, FEP, Kalrez., TTV, PTFE, GFT

### Operating Limits:

- Pressure : Full Vacuum to 25 Bar
- Temperature : 60°C to 200°C
- Shaft Dia : 30mm to 150mm



MANUFACTURER OF MECHANICAL SEALS  
& ENGINEERING PRODUCTS

# Seal Support System

## Thermosyphon System

Thermosyphon system is used for supplying buffer fluid & pressurizing double cartridge mechanical seals. Thermosyphon system are equipped with all necessary connections & fittings which is used for the storage, pressure maintenance and cooling of buffer fluid in cartridge mechanical seal.

The pressure of the barrier fluid is higher than the pressure of the fluid being sealed thus maintaining the temperature and pressure at the sealing area.

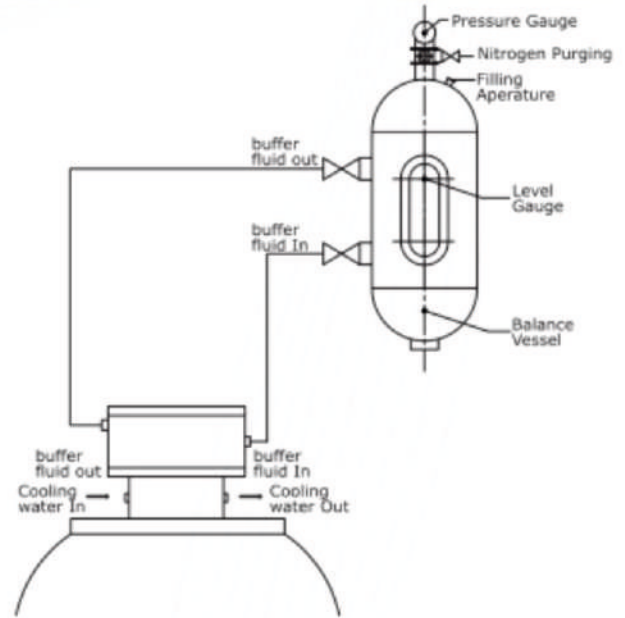

Feed pump is specially made for Thermosyphon vessel. This is normally recommended for API plan 53 or API plan 54. The function of the Feed Pump is to recharge the Thermosyphon vessel with additional quantity of barrier fluid when Thermosyphon is under pressure and liquid level is low due to mechanical seal failure.

### Material of Constructions :

Feed Pump Body : AISI 304, AISI 316  
Empty Weight : 3.5 kg (Approx.)

### Operating Limits :

Capacity : 3 Litre  
Design Pressure : 25 bar  
Hydraulic Test pressure : 20 bar  
Temperature : 100°C

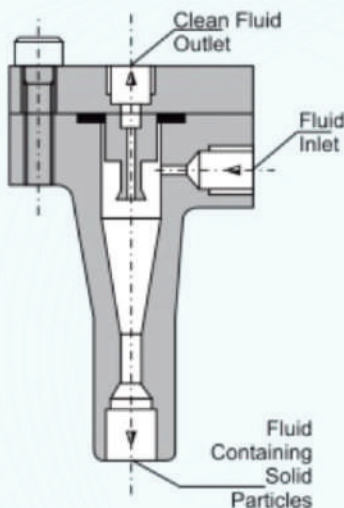

## Cyclon Separator

Cyclone Separator is used for separating dirt, sand particles from the injection blow to mechanical seal. The separation is obtained by centrifugal force generated by different pressure across the cyclone.

### Material of Constructions :

Feed Pump Body : AISI304 , AISI316  
Empty Weight : Teflon

### Operating Limits :

Density of solid particles has to be more than liquid.  
Pressure differential desired - 2 to 8.5 bar.

### Technical Specification :

Feed Pump Body : 1/2" NPT / 1/2" BSP  
Temp : 150°C  
Max. pressure : 80 bar

# Types of Mating Ring

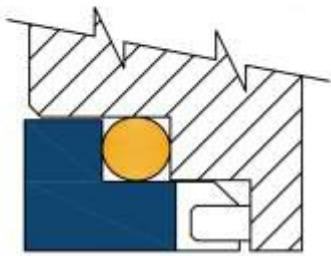

Type 1

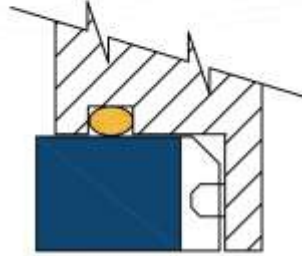

Type 2



Type 3

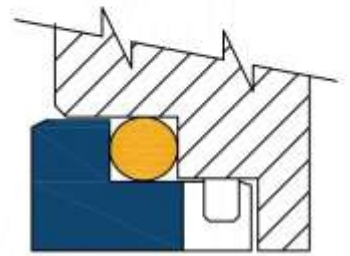

Type 4



Type 5



Type 6

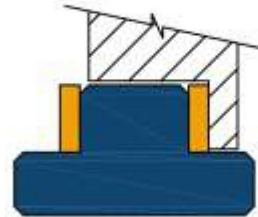

Type 7

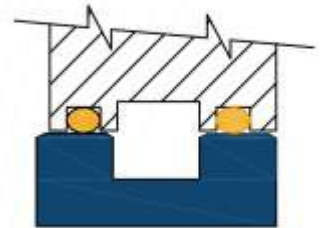

Type 8

## Elastomers & Sealing Faces



Carbon



Silicon Carbide



Graphoil Packings



O Rings



Ceramic



Tungsten Carbide

# Pump Process System

## Seal Fitment & Pump Process System

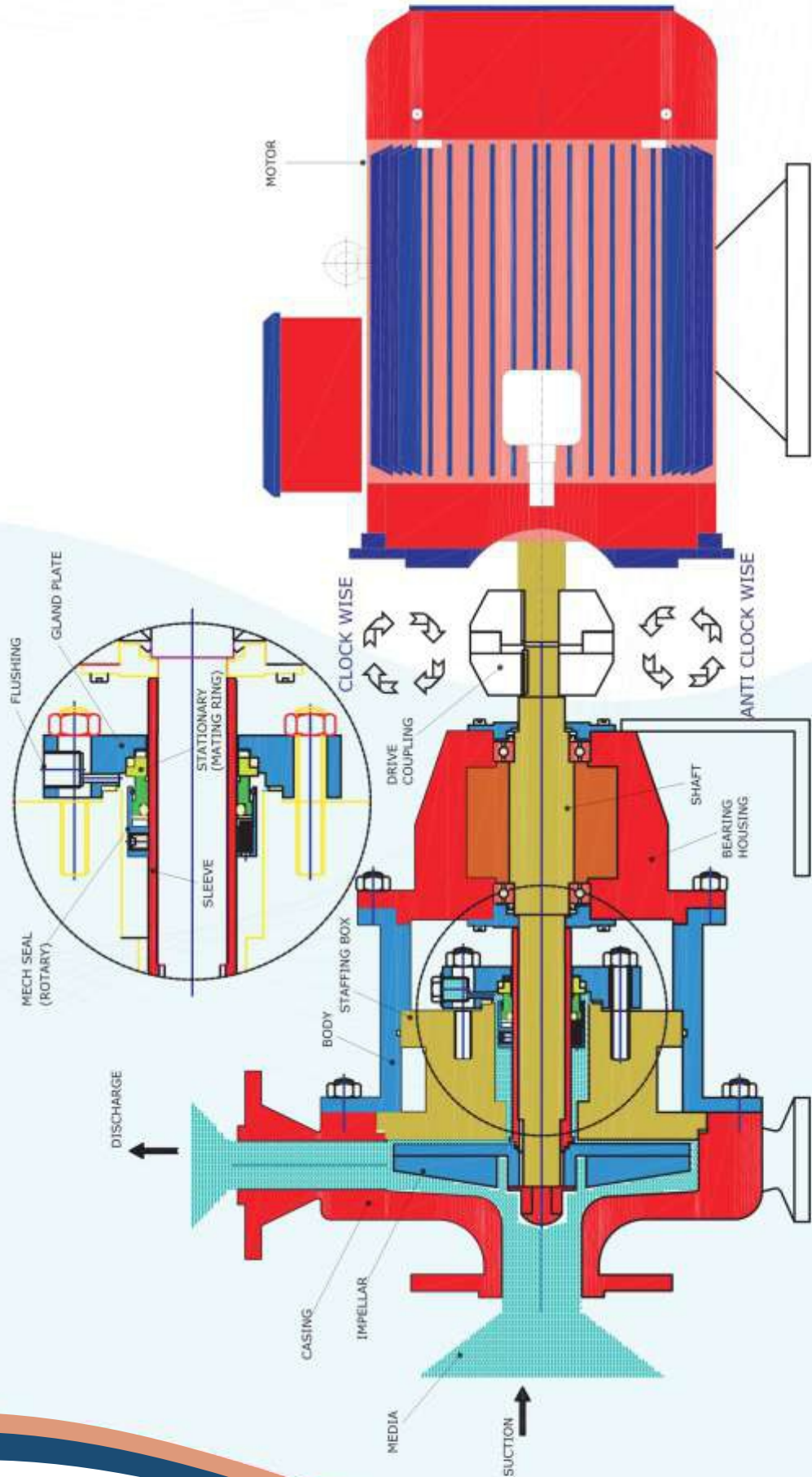

MANUFACTURER OF MECHANICAL SEALS  
& ENGINEERING PRODUCTS

# API Plan

## API Plan 1

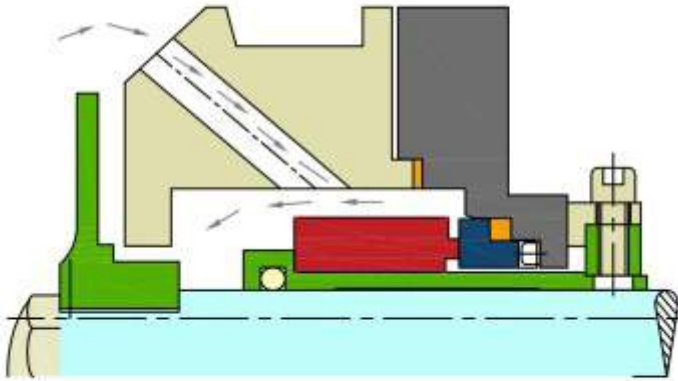

**Note :**

- Integral (Internal) Connection for flushing exists in stuffing box.
- Flushing connection need not be provided in the gland plate.

## API Plan 2

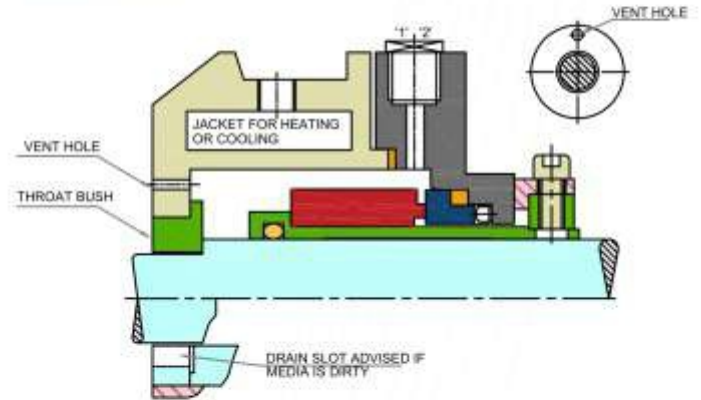

**Note :**

- Dead ended seal box with no circulation of flushed fluid, water cooled stuffing box jacket & throat bushing required when specified.
- Connection '1' & '2' Flugged for possible future circulation.

## API Plan 11

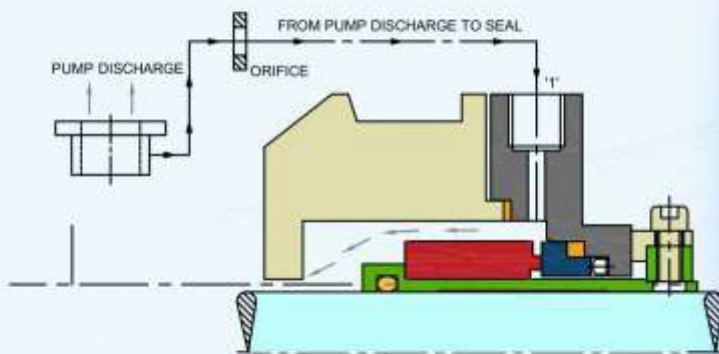

**Note :**

- Recirculation from pump case through orifice to seal.
- Connection '1' for flushing inlet.

## API Plan 13

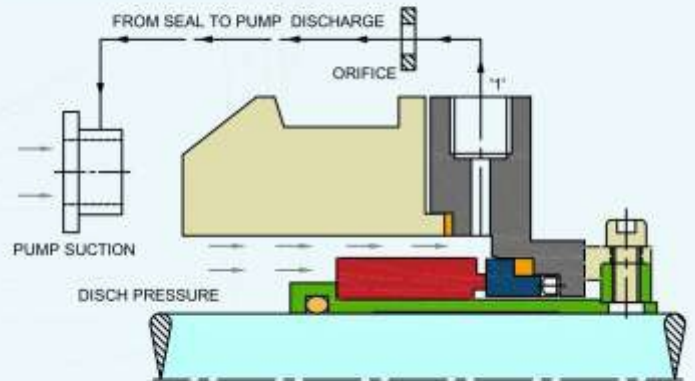

**Note :**

- Recirculation from seal chamber through orifice & back to pump suction.
- Connection '1' for flushing liquid circulation.

## API Plan 21

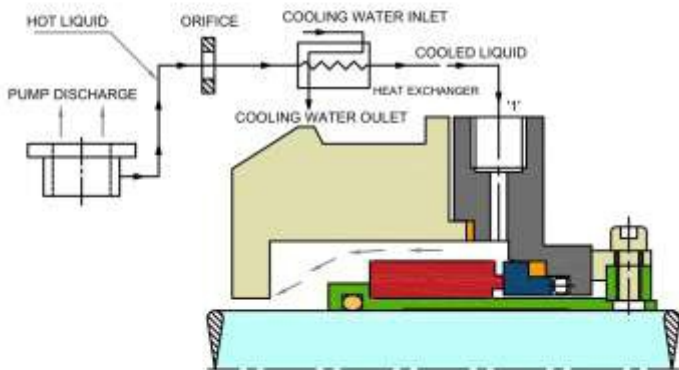

### Note :

- Recirculation from pump case through orifice and cooler to seal.
- Connection '1' for flushing inlet.

## API Plan 23

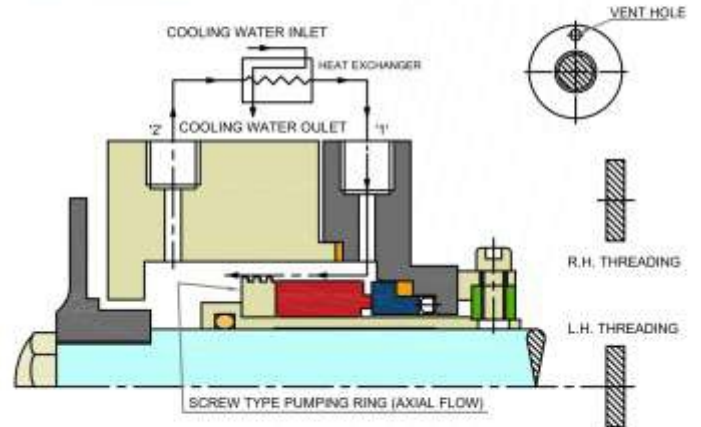

### Note :

- Recirculation from seal with pumping ring through cooler and back seal.
- Connection '1' & '2' for circulation inlet & outlet.

## API Plan 23

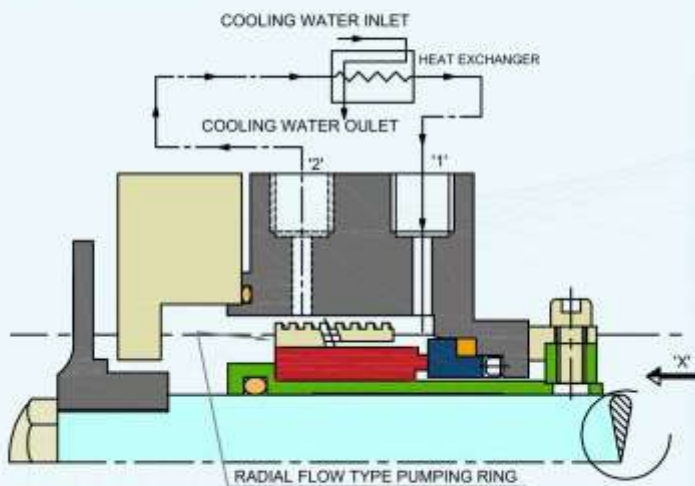

### Note :

- Connection '1' & '2' for flushing inlet & outlet for outboard seal.
- Non pressurized thermo syphon.

## API Plan 53

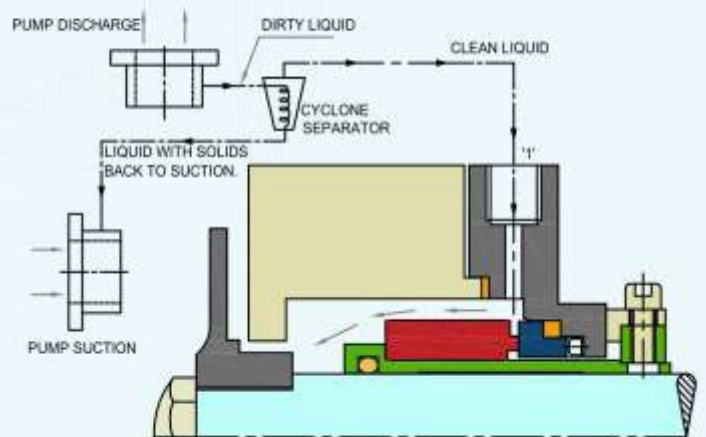

### Note :

- Connection '1'; for flushing inlet.
- Recirculation from pump case through cyclone separator delivering clean fluid through cooler to seal & fluid with solids back to pump suction.

## API Plan 32

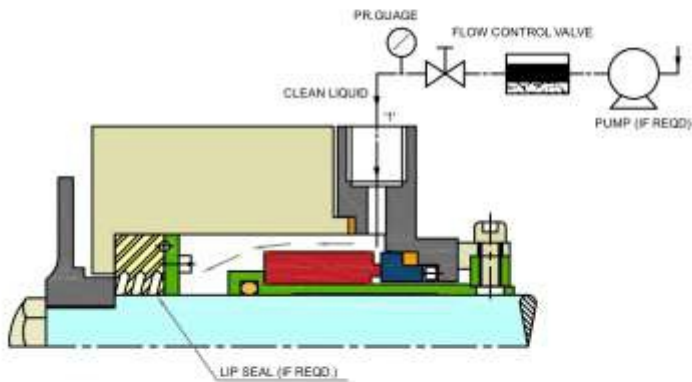

**Note :**

- Connection '1'; for flushing inlet.
- External liquid mixes in the pump media.
- Injection to seal from external source of clean liquid.
- The purchaser will specify the fluid characteristics and the vendor shall specify the volume pressure & temperature required.

## API Plan 41

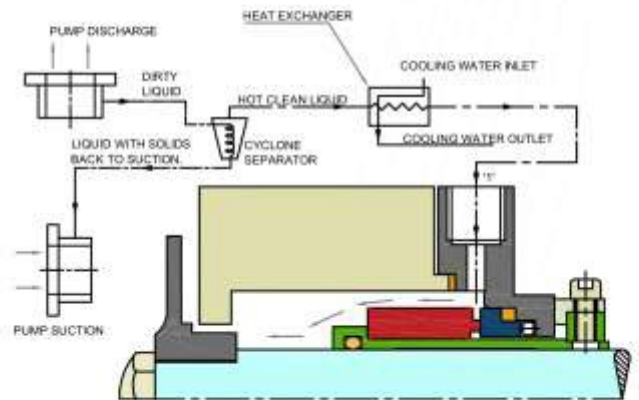

**Note :**

- Connection '1'; for flushing inlet.
- Recirculation from pump case through cyclone separator delivering clean fluid through cooler to seal & fluid with solids back to pump suction.

## API Plan 52

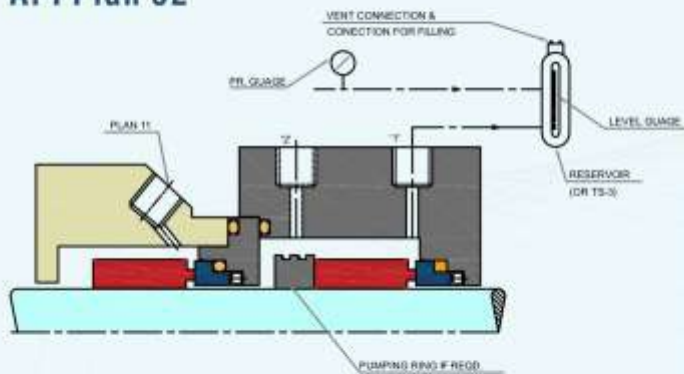

**Note :**

- Recirculation from pump case through orifice to seal.
- Connection '1' for flushing inlet.

## API Plan 53

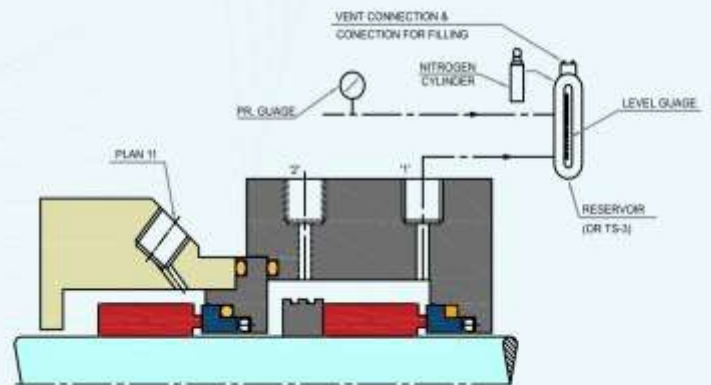

**Note :**

- Connection '1' & '2' for flushing inlet & outlet for outboard seal.
- Pressurized Thermo syphon.

# API Plan

## API Plan 54

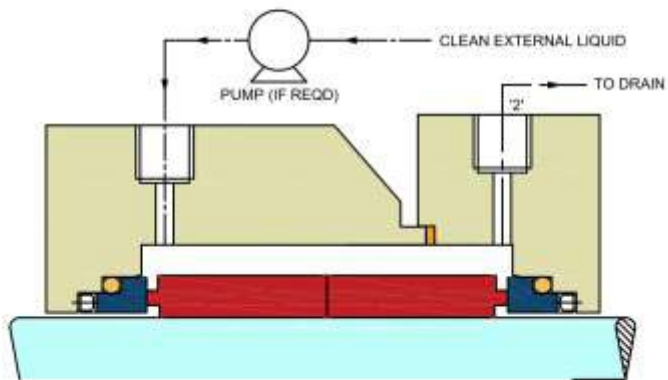

**Note :**

- Connection '1' & '2' for flushing inlet & outlet.

## API Plan 41

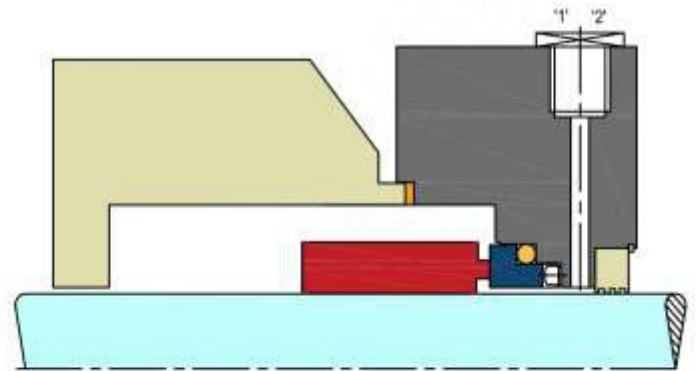

**Note :**

- Connection '1' & '2' for vent & drain.

## API Plan 52

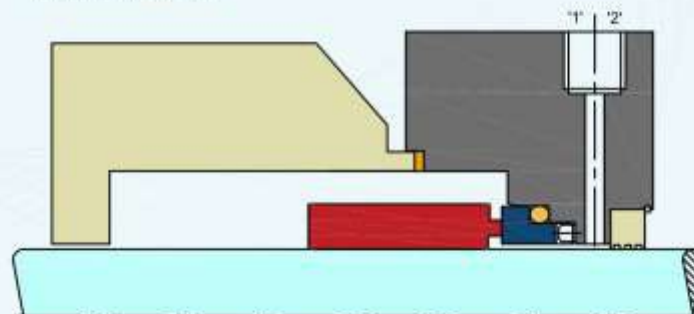

**Note :**

- Connection '1' & '2' for quenching inlet & outlet.

**Regd. Office & Works :**

Gala no 38, loheki chawl, momin estate,  
216/218 Moulana Azad Road, nagpada,  
mumbai 400 008

Email: [info@hvjsteel.com](mailto:info@hvjsteel.com)

Email: [sales@hvjsteel.com](mailto:sales@hvjsteel.com)

We reply within 24 hours

**PHONE**

+918655101559

+919892181817

